

USER MANUAL

INALTO?

INALTO.HOUSE

90cm Curved Glass Canopy Rangehood

MODEL CODE
IRHGC90



FOR ALL AUSTRALIAN HOMES

V1.2 | 0224

Welcome

Congratulations on purchasing your new appliance!

The InAlto brand is proudly distributed within Australia by Residentia Group Pty Ltd and within New Zealand by Applico Ltd.

Residentia Group Pty Ltd

ACN. 600 546 656

165 Barkly Avenue

Burnley, Victoria 3121

Australia

—

Applico Ltd

635 Great South Road

Penrose, Auckland 1061

New Zealand

—

InAlto

www.inalto.house

 /inalto.house

 /inalto.house

Please refer to the warranty card at the rear of this manual for information regarding your product's parts and labour warranty, or visit online at:

→ www.residentia.group

→ www.applico.co.nz

→ www.inalto.house

Both Residentia Group & Applico are customer obsessed and our Support Teams are there to ensure you get the most out of your appliance. Should you want to learn more about recommended usage, the various features of your appliance, and importantly taking care of the unit when cleaning, our Support Teams are here to help.

Telephone Contacts:

→ AU: 1300 11 4357

→ NZ: 0800 763 448

It is important that you read through the following use and care manual thoroughly to familiarise yourself with the installation and operation requirements of your appliance to ensure optimum performance.

Again, thank you for choosing an InAlto appliance and we look forward to being of service to you.

Contents

2 Welcome

4 Safety Instructions

8 Your InAlto Rangehood

10 Installation Instructions

14 Using Your Rangehood

15 Maintenance & Cleaning

17 Troubleshooting

18 Your Receipt

19 Purchase Details

20 Warranty Information

Customer Care

InAlto recommends the use of original spare parts. When contacting our customer service team on 1300 11 4357, please ensure that you have the following information at hand (which can be found on your appliances' rating plate).

- Model Number
- Serial Number

Safety Instructions

IMPORTANT INFORMATION

The following statements you will see in this booklet have these meanings:

WARNING: Indicating information concerning your personal safety.

CAUTION: Indicating information on how to avoid damaging the appliance or cabinetry.

IMPORTANT: Indicating tips and information about use of the cooker.

BEFORE USING YOUR APPLIANCE

This manual explains the proper use of your new InAlto rangehood. Please read this manual carefully before using the product. This manual should be kept in a safe place for handy reference. This rangehood (cooker hood) is a domestic appliance which has been manufactured and tested to comply with Australian and New Zealand Standard AS/NZS 60335.2.31.

This rangehood must only be installed in accordance with the instructions provided. Incorrect installation may cause harm to persons, damage property and void the product's warranty.

Read the following carefully to avoid damage or injury.

IMPORTANT: Check for any damage or marks. If you find the appliance is damaged or marked, you must report it within 7 days if you wish to claim for damage/ marks under the manufacturer's warranty. This does not affect your statutory rights.

WARNING: Follow these instructions carefully to avoid an electric shock or fire.

- Young children should be supervised to ensure they do not play with the cooker hood.
- This appliance is not intended for use by persons (including children) with reduced physical, sensory or mental capabilities, or lack of experience and knowledge, unless they have been given supervision or instruction concerning the use of the appliance by a person responsible for their safety.

- Ensure the cooker hood is switched off before carrying out maintenance, to avoid any possibility of electric shock.
- Never carry out flambé cooking under the cooker hood.
- This cooker hood is not suitable for use over barbecues.
- This cooker hood cannot be installed for external use- only to be installed indoors.
- The Aluminium grease filters must be removed every four weeks (at a maximum) for cleaning to reduce the risk of fire.
- The exhaust from the cooker hood must not be discharged into any heating flue, which may carry combustion products from other sources. (Figure 1)
- Exhaust air must not be discharged into a wall cavity, unless the cavity is designed for the purpose.
- There shall be adequate ventilation of the room when the range hood is used at the same time as appliances burning gas or other fuels (not applicable that only discharge the air back into the room).
- Regulations concerning the discharge of air have to be fulfilled.
- There must be adequate ventilation of the room when the cooker hood is used at the same time as appliances burning gas or other fuels.
- Your new rangehood is guaranteed against electrical or mechanical defects, subject to certain exclusions that are noted in the Warranty Terms and Conditions (at the rear of this user manual). The foregoing does not affect your statutory rights.
- Always cover lit gas burners with pots or pans when cooker hood is in use.
- Always switch off gas burners before you remove pots or pans.
- Do not leave lit gas burners exposed due to the risk of fire. (Figure 2)

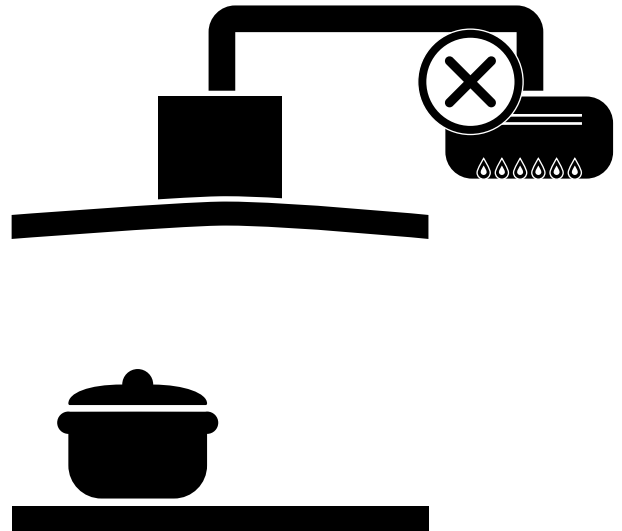

Figure 1

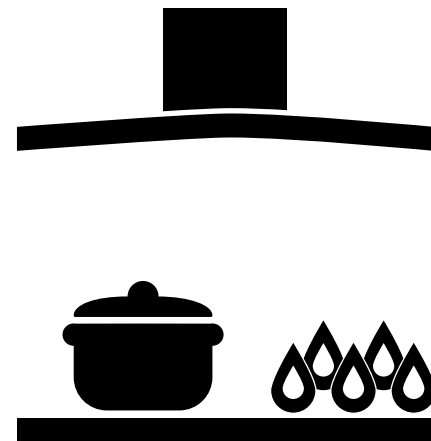

Figure 2

Safety Instructions (Continued)

ELECTRICAL CONNECTION

Check that the mains voltage matches with the voltage on the data plate inside the cooker hood. Check that the installation complies with standards of local building, gas and electrical authorities. Before connecting to the mains supply ensure that the mains voltage corresponds to the voltage on the rating plate inside the cooker hood.

WARNING: If the supply cord is damaged, it must be replaced by the manufacturer or its service agent or similarly qualified person in order to avoid a hazard.

WARNING: All electrical work must be done in accordance with local and national electrical codes as applicable and should be undertaken by licenced and qualified persons only.

SAFETY WARNINGS – FOR THE INSTALLER

When installing the cooker hood, make sure you adhere to the minimum and maximum distances from the cooker hood base to the cook top surface (as per table on page 10)

Exhaust flue installation:

The following rules must be strictly followed to obtain optimal air extraction.

- Keep exhaust flue short and straight.
- Do not reduce the size or restrict exhaust flue.
- Keep bends in the exhaust flue to a minimum; the more bends the lower the extraction performance.
- When using flexible flue always install duct with helix pulled taut to minimise pressure loss.
- Failure to observe these basic instructions will drastically reduce the performance and increase the noise levels of the cooker hood.

Exhaust air must not be discharged into a wall cavity, unless the cavity is designed for that purpose. The exhaust from the cooker hood must not be discharged into any heating flue, which may carry combustion products from other sources.

NOTE: Some installations may require the expandable/telescopic ducting to be cut to length. Cut with sharp tin snips or a fine-tooth hack saw blade, taking care not to distort or dent the exhaust cover. Where using expandable ducting, it's important to have the ducting fully taught to maximise efficiency of the airflow.

UNPACKING

During transportation, protective packaging was used to protect the appliance against any damage. After unpacking, please dispose of all elements of packaging in a way that will not cause damage to the environment.

All materials used for packaging the appliance are environmentally friendly; they are 100% recyclable and are marked with the appropriate symbol.

CAUTION: During unpacking, the packaging materials (polythene bags, polystyrene pieces, etc.) should be kept out of reach of children.

DISPOSAL OF THE APPLIANCE

Old appliances should not simply be disposed of with normal household waste and should be delivered to a collection and recycling centre for electric and electronic equipment. A symbol shown on the product, the instruction manual or the packaging shows that it is suitable for recycling.

Materials used inside the appliance are recyclable and are labelled with information concerning this. By recycling materials or other parts from used devices you are making a significant contribution to the protection of our environment.

Information on appropriate disposal centres for used devices can be provided by your local authority.

Your InAlto Rangehood

YOUR RANGEHOOD

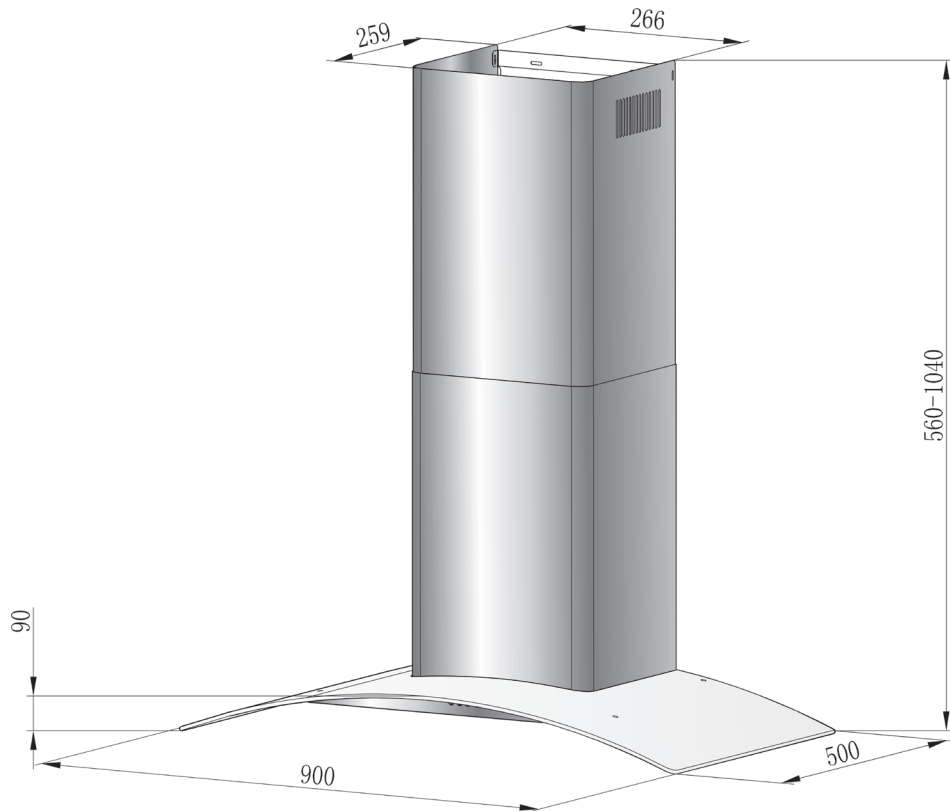

SPECIFICATIONS

MODEL	IRHGC90
Dimensions (W x D x H)	900mm x 500mm x 560-1040mm
Extraction	750m ³ /hr
Weight (Net/Gross)	15.8/19.2kg
Speed Settings	3 speeds push button control
Lighting	LED, 2 x 2W
Aluminium Filters	2
Power supply	220-240 Volts 50Hz Connects to standard household 10 Amp power point

RANGEHOOD COMPONENTS

Your InAlto Curved Glass Rangehood is supplied with:

- 1 × Rangehood
- 1 × Expandable 150mm ducting adapter
- 1 × Pack of fasteners and wall plugs
- 2 × Stainless Steel flue pieces (upper and lower)
- 1 × Wall Bracket (“hook”) for the rangehood
- 1 × Wall Bracket for the inside of the chimney pieces
- 1 × “Outside Chimney” bracket
- 1 × User Manual
- 1 × Quick Start Guide
- 1 × User Manual

ADDITIONAL ITEMS REQUIRED FOR INSTALLATION

- Duct tape or cable ties
- Ducting relevant to your installation requirements (including any rigid bends, vents and/or adapters)
- Drill and/or screwdriver
- Spirit Level
- Tape Measure
- Jigsaw
- Ladder

OPTIONAL ACCESSORIES

Residentia Group (Australia) and Applico (NZ) sell the following optional accessories, which can be purchased separately by contacting our After Sales Service Team.

- Carbon Filter
- Various ducting solutions (rigid ducting, adapters, vents/outlets and elbow bends)

Installation Instructions

WARNING: Before starting the installation, please refer to the Safety Information section.

- Always switch the power off prior to beginning the installation.
- Stainless steel is very easily damaged during installation.
- Wherever possible, protect the rangehood with the cardboard box or plastic
- A power point must be located within 1.5m of the power cord exit from the rangehood, and it should be always accessible to allow isolation from power during cleaning or maintenance.
- A 150mm round ducting adapter is supplied, however all other ducting accessories are not.
- All ducting must comply with building codes and local requirements.
- If you are re-circulating the air, rather than ducting, please ensure that the side outlet grilles are not obstructed in any way as this will affect the efficiency of the rangehood.
- Ensure that the rangehood is mounted in a level position, both horizontally and vertically. This is essential to ensure the rangehood operates correctly and prevents grease build up at one end.

IMPORTANT: Never use a silicone around your rangehood or flue pieces. Never install the rangehood or flue pieces into the plaster ceiling which prevents easy access to the rangehood for servicing requirements.

IMPORTANT: Before installing your rangehood, please record the details of your rangehood's rating label (located within the rangehood, behind the aluminium grease filters) into the form on page 19. This will be helpful should you need to contact our service team in the future.

POSITIONING THE RANGEHOOD

IMPORTANT: The height of the rangehood underside must be a minimum of 600mm* to a maximum 800mm from the top of your cooktop surface (for gas cooktops this is the top of the gas burner).

* If the installation instructions for your cooktop specify a greater distance than the minimum, then that shall be the minimum height for installation.

COOKTOP FUEL TYPE:	DIMENSION A	
	Minimum*	Maximum
Gas (multiple burners with maximum 45.4 MJ/h total output and no single burner exceeding 16.2 MJ/h output)	650mm	800mm
Gas (multiple burners with total output greater than 45.4 MJ/h but less than 77.8 MJ/h, and no single burner exceeding 17.3 MJ/h output)	760mm	800mm
Gas (single burner not exceeding 21.6 MJ/h output)	650mm	800mm
Gas (single burner with an output greater than 21.6 MJ/h but not exceeding 29.2 MJ/h)	760mm	800mm
Electric	600mm	800mm

INSTALLATION PREPARATION

Before beginning the installation of your rangehood, the method of ducting should be considered and selected. The guide below illustrates the various ducting options.

This rangehood cannot be operated in recirculation mode. We recommend to duct wherever possible.

Please follow the below tips on how to correctly duct your rangehood:

- Always use correctly sized ducting.
- Do not reduce the size of the ducting.
- Always use solid ducting.
- Always use non-flammable ducting.
- Always duct to the outside atmosphere.
- Do not use flexible ducting.
- Do not duct into the ceiling space. Always vent to the outside atmosphere.
- Avoid sharp 90 degree bends as much as possible. Use 45 degree bends instead wherever possible.
- Duct to the outside atmosphere using the shortest duct run possible.
- Use cylindrical ducting whenever possible.

Ducting Options

1. Into your ceiling cavity and then vented through your eaves.



2. Straight up and through your tiled or metal roof.



3. Through your wall.



Installation Instructions (Continued)

INSTALLATION STEPS

- Once you've determined your installation height, drill 3 × 8mm holes to install the mounting bracket (hook) onto the wall ensuring that it's secured in a level position. Tighten the bracket with the screw plug and screw provided (See Figure 3).
- When finished, line up the hood and hang onto the wall bracket hook (See Figure 4).
- After hanging the hood on the bracket, remove the filters, mark 2 holes inside the hood for safety screws. After marking, remove the hood, drill two holes and insert 2 wall plugs and finally fix the safety screws with 2 screws (ST4×30mm) (See Figure 5).
- Place the plastic duct on the cooker hood (See Figure 6)
- The lower chimney bracket is used to fix the upper decorative chimney and lower decorative chimney. Use 2pcs 4×8mm screws to attach lower chimney and lower chimney bracket together. Put the lower chimney on the cooker hood and mark the location of lower chimney bracket fixing holes on the wall. Fix the lower chimney bracket on the wall by 2 screws (4mm x30mm) (See Figure 7).
Note: Do not fasten screws too tightly to allow the upper decorative chimney to be telescopically adjusted after assembled.
- Then pulling out the upper chimney upwards to the target height. Adjust to reach the height required. Fix the upper chimney on the upper chimney bracket by 2 screws (4×8mm). Then fix the upper chimney bracket on the wall.
Before fixing the bracket on the wall, you can decide the upper chimney bracket fixing holes for installation (See Figure 8).

WARNING: Failure to install the screws or fixing device in accordance with these instructions may result in electrical hazards. The warning shall be in the same part of the instructions that include details of how to mount the equipment.

Figure 3

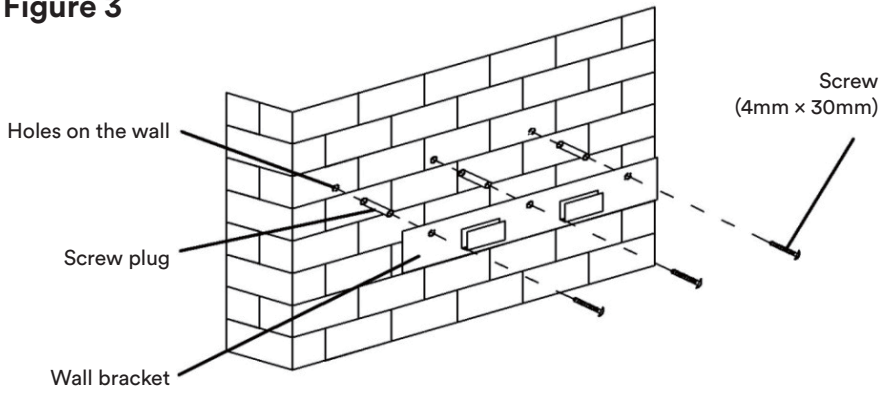

Figure 4

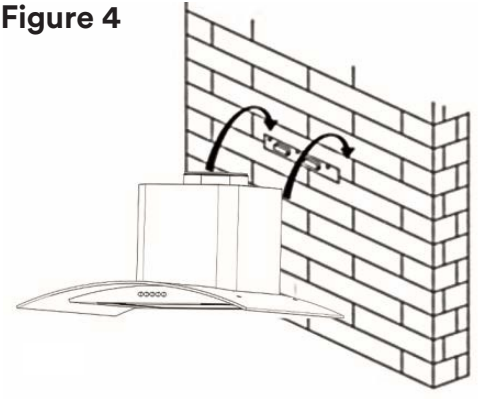

Figure 5

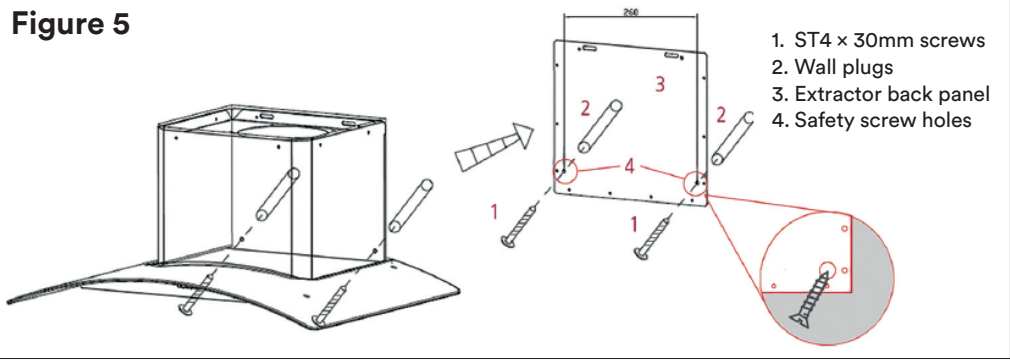

Figure 6

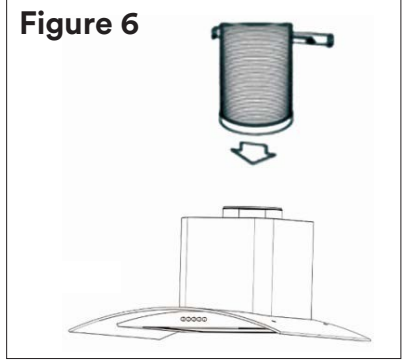

Figure 7

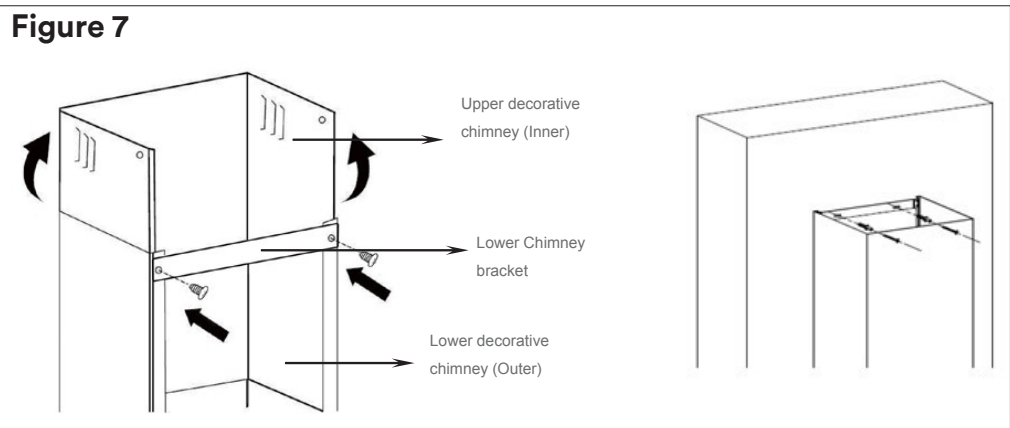
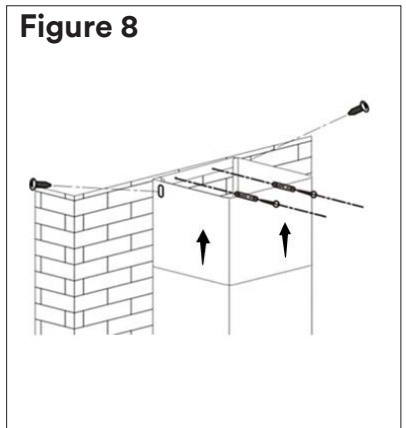

Figure 8



Using Your Rangehood

CONTROLS

Your Curved Glass Rangehood features push button controls (Figure 9) with three speed levels of extraction.

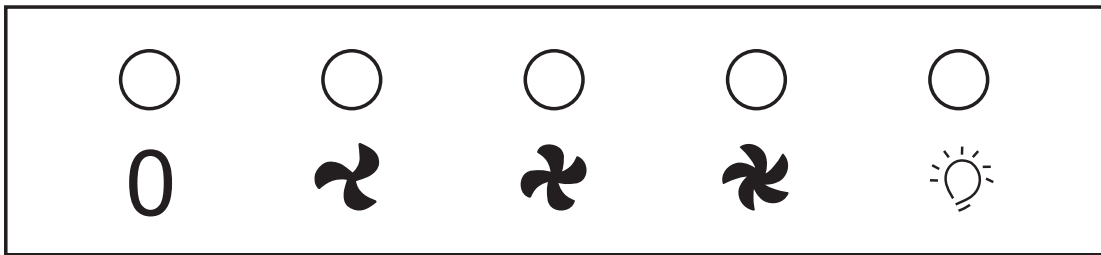

Figure 9

SPEED SETTINGS

- Push the 'Low' button, and the rangehood will operate at low speed.
Ideal for light frying, simmering water, etc.
- Push the 'Mid' button, and the rangehood will operate at a medium speed.
Ideal for frying, wok cooking, heavy boiling water, etc.
- Push the 'High' button, and the rangehood will operate at a high speed.
Ideal for Grilling, intensive frying, wok cooking, stir frying, etc.
- Push the 'Stop' button to switch the rangehood fan Off.

LIGHTS

- Push the 'Light' button and the two LED lights will come on.
To turn the lights off, simply push the 'Light' button again.

Maintenance & Cleaning

CAUTION:

- Before maintenance or cleaning is carried out, the rangehood should be disconnected from the main power supply. Ensure that the cooker hood is switched off at the wall socket and the plug removed.
- Stainless steel is susceptible to scratches and abrasions, so please follow the cleaning instructions to ensure the best possible result is achieved without damage.
- The instructions within this manual must be followed to avoid a fire risk.
- Keep the motor and other spare parts free from water, as this will cause damage to the appliance.

ALUMINIUM GREASE FILTER

- To remove the Aluminium grease filter, use a finger to pull the small locking latch on each filter to release it from the rangehood body. Be careful, as the filter can easily drop down once released and scratch or damage your cooktop.
- Your aluminium filters can be washed by hand in warm soapy water. For stubborn grease stains use a soft nylon brush to help remove these stains. After cleaning, allow the filters to completely dry before refitting into your rangehood.

CAUTION: We do not recommend washing the Aluminium filters within a dishwasher. This can damage the filter and cause a discolouration of the filter.

STAINLESS STEEL SURFACES

Clean stainless steel surfaces using non-abrasive cleaning products that are specifically for use on stainless steel. To ensure best results also use an even pressure and follow the grain of the stainless steel. Use of a soft cloth reduces the risk of scratching. If the cloth is wet, ensure that a dry soft cloth is used to wipe down the surface again reducing the risk of any surface rust appearing.

CONTROL PANEL SURFACE

The control panel can be cleaned using warm soapy water. Ensure the cloth is well wrung before cleaning. Use a dry soft cloth to remove any excess moisture left after cleaning.

CHANGING A LIGHT GLOBE

The LED lights should not require service. If there is an issue with a light, please contact our After Sales Service Team.

CHARCOAL FILTERS

If your rangehood has been installed in recirculating mode, you should be using the Charcoal Filter accessories available for purchase separately. These filters can not be re-used or cleaned and as a general rule the activated charcoal filter should be replaced every 3 months (or more frequently depending on the amount and type of cooking you do).

To order a replacement filter, please contact our After Sales Service Team.

THIS PAGE IS INTENTIONALLY LEFT BLANK

Troubleshooting

OPERATION IN CASE OF EMERGENCY

In the event of an emergency you should:

- Switch off all rangehood controls.
- Switch the rangehood off at the power outlet and immediately unplug.
- Call After Sales Support.

Some minor faults can be fixed by referring to the instructions given in the table below.

IMPORTANT: If your appliance appears to be operating incorrectly, then you should disconnect it from your electrical supply and then contact After Sales Support.

WARNING: Do not attempt to repair the rangehood yourself.

Please note that if an engineer is asked to attend whilst the product is under warranty and finds that the problem is not the result of an appliance fault, then you may be liable for the cost of the call out charge.

The appliance must be accessible for the engineer to perform any necessary repair.

If your appliance is installed in such a way that an engineer is concerned that damage will be caused to the appliance or your kitchen, then they will not complete a repair. This includes situations where the rangehood has been tiled in or sealed in with a sealant.

Please refer to the conditions of that appear on the warranty card at the rear of this user manual.

FAULT	COMMON CAUSE	COMMON SOLUTIONS
The lights work, however the motor does not work	The motor is blocked or jammed.	Call After Sales Support for further guidance.
	The capacitor is damaged.	
Neither the lights nor the motor works	Beside the above mentioned, check the following:	
	Light globes are damaged or blown	Call After Sales Support for further guidance.
	The power cord is loose.	Ensure that the rangehood is correctly plugged in and the power outlet is switched on.
The rangehood is vibrating against the wall or cupboard	The rangehood undermount is not fixed correctly.	Ensure that the internal safety screws have been used and are tight.
Insufficient suction	The distance between the rangehood and your cooktop is too great.	Have your installer re-adjust the installation position, ensuring that the minimum distances are observed as per the building code and relevant standards.
	Ducting is loose, kinked, too long or too many bends.	Check that your rangehood has been ducted correctly and in accordance with the installation instructions.

Attach your receipt
to this page



Purchase Details

For future reference, please record the following information in the form below. The product details can be found on the rating plate (located within the rangehood, behind the aluminium grease filter), installation details and purchase details which can be found on your sales invoice.

STORE DETAILS

STORE NAME | _____

ADDRESS | _____

TELEPHONE | _____ PURCHASE DATE | _____

PRODUCT DETAILS

MODEL NO. | _____

SERIAL NO.* | _____

INSTALLATION DETAILS

DATE OF INSTALLATION | _____

INSTALLED BY | _____

Warranty Information

AUSTRALIAN WARRANTY TERMS & CONDITIONS RANGEHOOD APPLIANCES

This document sets out the terms and conditions of the product warranties for Residentia Group Appliances. It is an important document. Please keep it with your proof of purchase documents in a safe place for future reference should you require service for your Appliance.

1. IN THIS WARRANTY

- (a) 'acceptable quality' as referred to in clause 10 of this warranty has the same meaning referred to in the ACL;
- (b) 'ACL' means Trade Practices Amendment (Australian Consumer Law) Act (No.2) 2010;
- (c) 'Appliance' means any Residentia Group product purchased by you accompanied by this document;
- (d) 'ASR' means Residentia Group authorised service representative;
- (e) 'Residentia Group' means Residentia Group Pty Ltd of 165 Barkly Avenue Burnley VIC, ACN 600 546 656 in respect of Appliances purchased in Australia;
- (f) 'major failure' as referred to in clause 10 of this warranty has the same meaning referred to in the ACL and includes a situation when an Appliance cannot be repaired or it is uneconomic for Residentia Group, at its discretion, to repair an Appliance during the Warranty Period;
- (g) 'Warranty Period' means:
 - (i) where the Appliance is used for personal, domestic or household use (i.e. normal single family use) as set out in the instruction manual, the Appliance is warranted against manufacturing defects for 24 months (or 36 months where a valid extended warranty registration has occurred), following the date of original purchase of the Appliance;
 - (h) 'you' means the purchaser of the Appliance not having purchased the Appliance for re-sale, and 'your' has a corresponding meaning.
2. This warranty only applies to Appliances purchased and used in Australia and is in addition to (and does not exclude, restrict, or modify in any way) any non-excludable statutory warranties in Australia.
3. During the Warranty Period Residentia Group or its ASR will, at no extra charge if your Appliance is readily accessible for service, without special equipment and subject to these terms and conditions, repair or replace any parts which it considers to be defective. Residentia Group or its ASR may use remanufactured parts to repair your Appliance. You agree that any replaced Appliances or parts become the property of Residentia Group. This warranty does not apply to light globes, batteries, filters or similar perishable parts.
4. Parts and Appliances not supplied by Residentia Group are not covered by this warranty.
5. You will bear the cost of transportation, travel and delivery of the Appliance to and from Residentia Group or its ASR. If you reside outside of the service area, you will bear the cost of:
 - (a) travel of an authorised representative;
 - (b) transportation and delivery of the Appliance to and from Residentia Group or its ASR, in all instances, unless the Appliance is transported by Residentia Group or its ASR, the Appliance is transported at the owner's cost and risk while in transit to and from Residentia Group or its ASR.
6. Proof of purchase is required before you can make a claim under this warranty.
7. You may not make a claim under this warranty unless the defect claimed is due to faulty or defective parts or workmanship. Residentia Group is not liable in the following situations (which are not exhaustive):

-
- (a) the Appliance is damaged by:
- (i) accident
 - (ii) misuse or abuse, including failure to properly maintain or service
 - (iii) normal wear and tear
 - (iv) power surges, electrical storm damage or incorrect power supply
 - (v) incomplete or improper installation
 - (vi) incorrect, improper or inappropriate operation
 - (vii) insect or vermin infestation
 - (viii) failure to comply with any additional instructions supplied with the Appliance;
- (b) the Appliance is modified without authority from Residentia Group in writing;
- (c) the Appliance's serial number or warranty seal has been removed or defaced;
- (d) the Appliance was serviced or repaired by anyone other than Residentia Group, an authorised repairer or ASR.
8. This warranty, the contract to which it relates and the relationship between you and Residentia Group are governed by the law applicable where the Appliance was purchased.
9. To the extent permitted by law, Residentia Group excludes all warranties and liabilities (other than as contained in this document) including liability for any loss or damage whether direct or indirect arising from your purchase, use or non use of the Appliance.
10. For Appliances and services provided by Residentia Group in Australia, the Appliances come with a guarantee by Residentia Group that cannot be excluded under the Australian Consumer Law. You are entitled to a replacement or refund for a major failure and for compensation for any other reasonably foreseeable loss or damage. You are also entitled to have the Appliance repaired or replaced if the Appliance fails to be of acceptable quality and the failure does not amount to a major

failure. The benefits to you given by this warranty are in addition to your other rights and remedies under a law in relation to the Appliances or services to which the warranty relates.

11. At all times during the Warranty Period, Residentia Group shall, at its discretion, determine whether repair, replacement or refund will apply if an Appliance has a valid warranty claim applicable to it.
12. Missing parts are not covered by warranty. Residentia Group reserves the right to assess each request for missing parts in a case by case basis. Any parts that are not reported missing in the first week after purchase will not provide free of charge.
13. To enquire about claiming under this warranty, please follow these steps:
- (a) carefully check the operating instructions, user manual and the terms of this warranty;
 - (b) have the model and serial number of the Appliance available;
 - (c) have the proof of purchase (e.g. an invoice) available;
 - (d) telephone the numbers shown below.
14. You accept that if you make a warranty claim, Residentia Group and its ASR may exchange information in relation to you to enable Residentia Group to meet its obligations under this warranty.

IMPORTANT

Before calling for service, please ensure that the steps in point 13 have been followed.

Telephone contact

- Service: Please call 1300 11 HELP (4357)

The Australian Consumer Law requires the inclusion of the following statement with this warranty:

Our goods come with guarantees that cannot be excluded under the Australian Consumer Law. You are entitled to a replacement or refund for a major failure and for compensation for any other reasonably foreseeable loss or damage. You are also entitled to have the goods repaired or replaced if the goods fail to be of acceptable quality and the failure does not amount to a major failure.

THIS PAGE IS INTENTIONALLY LEFT BLANK

Warranty Information

NEW ZEALAND WARRANTY TERMS & CONDITIONS COOKING APPLIANCES

To help care for your investment, be sure to register your appliance online. Registration will help you if you need to arrange service in the future, and serves as a record of your purchase – including critical information like model number and serial number – that you can refer to at any time.

Simply visit the below website, or ask your retailer for help: www.inalto.co.nz/register

WARRANTY:

These products are covered by a warranty for a period of 24 months from the date of purchase, subject to the following conditions*. The warranty covers rectification free of charge of any fault arising from defective materials or components, or faulty workmanship or assembly.

* The conditions above mentioned are:

1. That the purchaser carefully follows all instructions packed with the product;
2. That the purchaser and/or installer carefully follows the installation instructions provided and complies with electrical wiring regulations, gas and/or plumbing codes;
3. That the purchaser carefully follows instructions provided in the owner's handbook relating to the proper use and care of the product and does not use the product for any purpose other than the domestic use for which it has been designed;
4. Commercial use of the product for professional or industrial purposes will void this warranty.;
5. That the product was purchased and installed in New Zealand;
6. That this warranty does not extend to:
 - a) optional glass lids for hobs apart from claims which relate to mechanical or physical damage thereof at the date of purchase;
 - b) 'consumable' parts such as light bulbs or filters;
 - c) damage to ceramic glass caused by liquid or solid spill-overs, lack of maintenance, or impact;
 - d) damage to surface coatings caused by cleaning or maintenance using products not recommended by the owner's handbook;
 - e) defects caused by normal wear and tear, accident, negligence, alteration, misuse or incorrect installations;
 - f) a product dismantled, repaired or serviced by any serviceman other than an authorised service agent;

- g) a product not in possession of the original purchaser;
- h) damage caused by power outages or surges
- i) damage caused by pests (eg. rats, cockroaches etc.)

7. That if the product is a freestanding microwave oven or small appliance it must be returned to the dealer/retailer for servicing. These products, unless stated otherwise, have a 12 month warranty from original date of purchase with 24 months on the microwave magnetron; Waste disposers have a 12 month warranty.
8. The provision of service under this warranty is limited by a 25km boundary from the retailer where the product was purchased except for microwaves. Such travelling outside of these limits will incur commercial cost to be paid by you, regulated by the number of kilometres travelled beyond the 25km limit (50km return trip). Microwaves are to be delivered to the nearest authorised service agent by the customer.

Please refer to your user manual for any further conditions that may apply to your specific model.

Nothing herein contained shall be construed in any way as excluding or limiting your rights under the Consumer Guarantees Acts 1993.

For Service please visit www.applico.co.nz/service or contact the dealer/retailer from whom you purchased the product from or call the 0800 number listed below. If you are unable to establish the date of purchase, or the fault is not covered by this warranty, or if the product is found to be in working order, you will be required to bear all service call charges.

Registration of this warranty constitutes acceptance of the terms and conditions of this warranty.

Should you require any assistance, please call Customer Services on 0800 763 448.

Distributed by Applico Ltd.
www.applico.co.nz
July 2019

After registering your appliance online, we recommend you fill out the below information for your reference and keep this warranty card in a safe place.

THIS WARRANTY IS VALID IN NEW ZEALAND ONLY.

DESIGNED IN MELBOURNE

INALTO

FOR ALL AUSTRALIAN HOMES

WWW.INALTO.HOUSE



E2447