

USER MANUAL

INALTO?

INALTO.HOUSE

# 60cm & 70cm Gas Cooktops

MODEL CODE/S

ICG6F, ICGW61F, ICGW60S, ICGW70S



FOR ALL AUSTRALIAN HOMES

V2 | 0821

Welcome

**Residentia Group Pty Ltd**

ACN. 600 546 656

165 Barkly Avenue

Burnley, Victoria 3121

Australia

—

**Applico Ltd**

635 Great South Road

Penrose, Auckland 1061

New Zealand

—

**InAlto**

[www.inalto.house](http://www.inalto.house)

 /inalto.house

 /inalto.house

## Congratulations on purchasing your new Gas Cooktop!

The InAlto brand is proudly distributed within Australia by Residentia Group Pty Ltd and within New Zealand by Applico Ltd.

Please refer to the warranty card at the rear of this manual for information regarding your product's parts and labour warranty, or visit online at:

→ [www.residentia.group](http://www.residentia.group)

→ [www.applico.co.nz](http://www.applico.co.nz)

→ [www.inalto.house](http://www.inalto.house)

Both Residentia Group & Applico are customer obsessed and our Support Teams are there to ensure you get the most out of your appliance. Should you want to learn more about recommended usage, the various features of your appliance, and importantly taking care of the unit when cleaning, our Support Teams are here to help.

Telephone Contacts:

→ AU: 1300 11 4357

→ NZ: 0800 763 448

It is important that you read through the following use and care manual thoroughly to familiarise yourself with the installation and operation requirements of your appliance to ensure optimum performance.

Again, thank you for choosing an InAlto appliance and we look forward to being of service to you.

## Contents

<u>2</u>	<u>Welcome</u>
<u>4</u>	<u>Important Instructions</u>
<u>6</u>	<u>Your InAlto Cooktop</u>
<u>8</u>	<u>Before First Use</u>
<u>9</u>	<u>Using Your Cooktop</u>
<u>10</u>	<u>Burners</u>
<u>11</u>	<u>Cleaning and Care</u>
<u>12</u>	<u>Troubleshooting</u>
<u>13</u>	<u>Technical Data</u>
<u>14</u>	<u>Installation Instructions</u>
<u>16</u>	<u>Installation Procedure</u>
<u>18</u>	<u>Gas Connection</u>
<u>22</u>	<u>LPG Conversion</u>
<u>23</u>	<u>Electrical Connection</u>
<u>24</u>	<u>Testing Appliance Operation</u>
<u>26</u>	<u>Your Receipt</u>
<u>27</u>	<u>Purchase Details</u>
<u>28</u>	<u>Warranty Information</u>

## Customer Care

---

InAlto recommends the use of original spare parts. When contacting our customer service team, please ensure that you have the following information at hand (which can be found on your appliances' rating plate).

- Model Number
- Serial Number

# Important Instructions

---

## IMPORTANT INFORMATION

The following statements you will see in this booklet have these meanings:

**WARNING:** Indicating information concerning your personal safety.

**CAUTION:** Indicating information on how to avoid damaging the appliance or cabinetry.

**IMPORTANT:** Indicating tips and information about use of the cooker.

## CONDITIONS OF USE

This appliance is intended to be used in domestic environments (i.e. households) and similar applications such as:

- Staff kitchen areas in shops, offices and other working environments
- By clients in hotels, motels and other residential type environments
- Farm houses
- Bed and breakfast type environments
- Catering and similar non-retail applications

## BEFORE USING YOUR APPLIANCE

Before you use the appliance, we recommend that you read through the relevant sections of this manual, which provides the description of your appliance and its functions.

To avoid the risks that are always present when you use an appliance, it is important that the appliance is installed correctly and that you read the safety instructions carefully to avoid misuse and hazards.

We recommend that you keep this instruction booklet for future reference and pass it on to any future owners.

This appliance complies with the requirements of Australian and New Zealand Standard AS/NZS 5263.

**IMPORTANT:** Check for any damage or marks. If you find the appliance is damaged or marked, you must report it within 7 days if you wish to claim for damage/ marks under the manufacturer's warranty. This does not affect your statutory rights.

## INFORMATION ON DISPOSAL FOR USERS

- Most of the packaging materials are recyclable. Please dispose of these materials through your local recycling depot or by placing them in appropriate collection containers.
- If you wish to discard this product, please contact your local authorities and ask for the correct method of disposal.

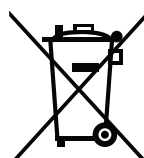

---

**WARNING:** Read the following carefully to avoid damage or injury.

- Do not allow pots to boil dry, as damage to both pan and cooktop may result.
- Do not operate the cooktop for an extended period without a pot or pan on the burner.
- Do not allow large cookware to overhang the cooktop onto adjacent benchtop. This will cause scorching to the benchtop surface.
- Do not allow cooking pots or pans to intrude into the area which is close to the controls.
- Ensure burner bodies and trivets are properly located on the cooktop (i.e. correctly assembled and positioned).

**CAUTION:** Read the following carefully to avoid an electric shock or fire.

It is important to use your cooktop safely. Check these safety points before using your cooktop.

- This appliance is not intended for use by persons (including children) with reduced physical, sensory or mental capabilities, or lack of experience and knowledge, unless they have been given supervision or instruction concerning use of the appliance by a person responsible for their safety.
- Children should be supervised to ensure they do not play with this appliance.
- During use, this appliance becomes hot. Care should be taken to avoid touching hot surfaces. To avoid burns, young children should be kept away.
- This appliance must not be used as a space heater.
- Keep vents clear of obstructions.
- In order to avoid a fire, this appliance must be kept clean.
- Do not spray aerosols in the vicinity of this appliance while it is in operation.
- Do not store flammable materials on or under this appliance, e.g. aerosols.
- Do not remove the trivet and enclose the burner with a wok stand as this will concentrate and deflect heat onto the burner.
- Do not use large pots or heavy weights which can bend the trivet or deflect flame onto the burner.
- Do not place anything, e.g. asbestos mat between pan and trivet as serious damage to the cooktop may occur.
- For maximum stability, ensure pots and pans are centrally located on the trivets.
- Handles should be turned away from the front of the bench to avoid accidents.
- Do not modify this appliance.
- Only models fitted with flame safeguard can be used in marine craft, caravans or mobile homes.

# Your InAlto Cooktop

ICG6F

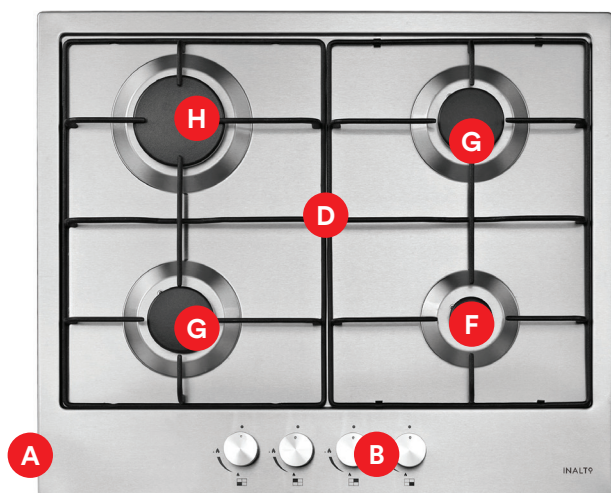

Figure 1A

ICGW61F



Figure 1B

ICGW60S

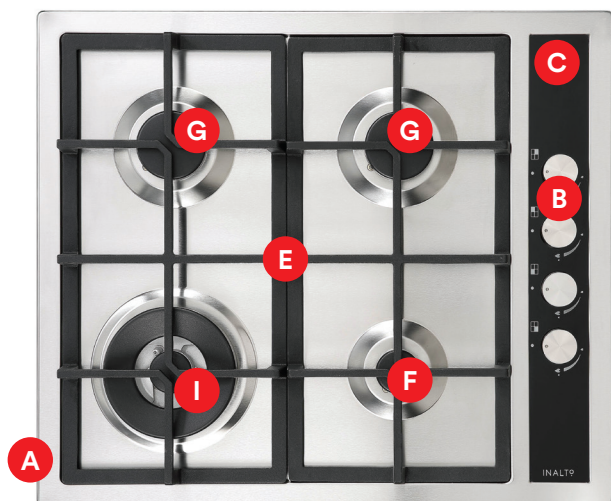

Figure 1C

ICGW70S

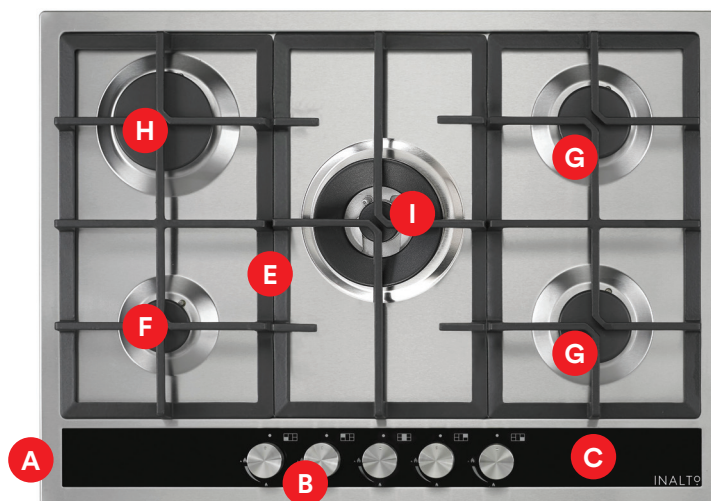

Figure 1D

## KEY

- A. Stainless Steel Hob
- B. Burner Control Knobs
- C. Glass Panel beneath Burner Control Knobs
- D. Enamel trivets
- E. Cast Iron Trivets
- F. Auxiliary Burner
- G. Semi Rapid Burner
- H. Rapid Burner
- I. Wok Burner

Note: The above diagrams are for explanatory purposes only.  
Your Gas Cooktop may appear slightly different, however the functions remain the same.

## THE BURNER

Figure 2A

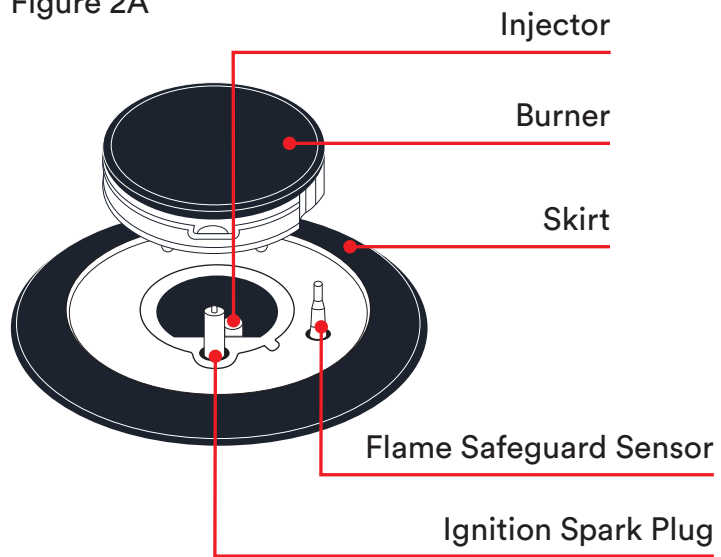
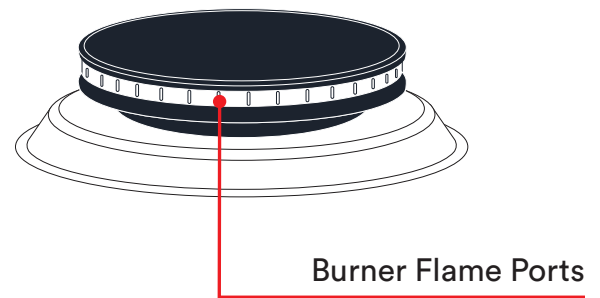

Figure 2B



# Before First Use

---

## INSTALLATION

- An authorised person must install this appliance and **MUST provide a Certificate of Compliance**. This certificate should be retained along with purchase information.
- Before using the appliance, ensure that all packing materials are removed from the appliance.
- In order to avoid any potential hazard, the installation instructions in this booklet, and any labels on the appliance must be followed.
- Ensure that all specified vents, openings and air spaces are not blocked.
- Where the appliance is built into a benchtop, the benchtop material must be capable of withstanding 85°C.
- Ensure that the duplicate rating label (in the instruction pack) is attached to a readily accessible adjacent surface, so that the cooktop can be easily identified in the case of a service call.

## SERVICING

- Servicing **MUST** only be carried out by authorised personnel.
- To maintain safe operation, it is recommended that the product be inspected every five years by an authorised service person.
- If the supply cord is damaged, it must be replaced by the manufacturer, its service agent or similarly qualified persons in order to avoid a hazard.

**WARNING:** Never install a cooktop that has been damaged. Please contact our Service Team for assistance.

## CLEANING

- Always ensure the appliance is turned off before cleaning.
- This appliance contains aluminium fittings. **Do not use caustic based cleaners.**
- Do not use steam cleaners as this may cause moisture build up on electrical components.
- Always clean the appliance immediately after any food spillage.
- Do not place any components in a dishwasher.
- Refer to the Cleaning and Care section on page 11 of this user manual for instructions on cleaning and maintaining your stainless steel hob panel.

**CAUTION:** Never place burners or trivets in a dishwasher.

## CONTROLS

Each burner is controlled by a control knob. The markings on the control panel indicate which burner the knob controls, and the setting for that burner. See Figure 3A or 3B depending on your model.

## LIGHTING BURNERS

Electronic ignition: These cooktops are fitted with mains powered ignition. When the appliance has been connected and the power is on, depressing any knob will release sparks to all burners.



# Using Your Cooktop

## STANDARD BURNER

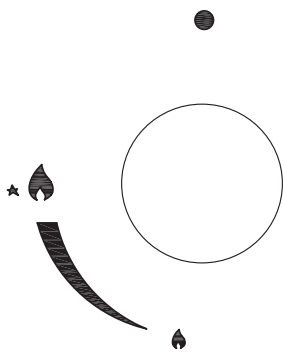

Figure 3A

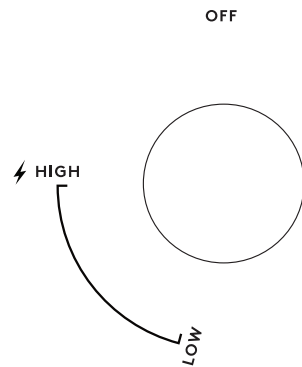

Figure 3B

## CAUTION:

- Keep hands clear of burners when lighting.
- If burner does not light within 5 seconds, turn knob to 'OFF' position, wait to allow gas to disperse and then try lighting again.
- Burners MUST be operated between 'HIGH' and 'LOW' settings only.

To light a burner, the knob must be turned to the ★ or ⚡ HIGH position, then pushed down as far as possible for approximately 5 seconds. If the flame goes out when the knob is released simply depress the knob again, this time holding it down with slightly more force for the same length of time.

The height of the flame can be varied by turning the control knob toward the 🔥 'LOW' position.

## TRIPLE RING WOK BURNER

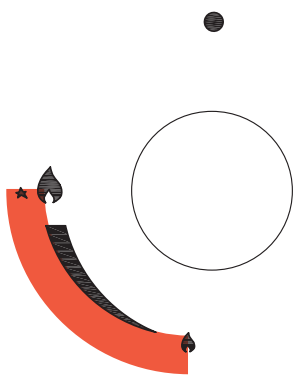

Figure 3C

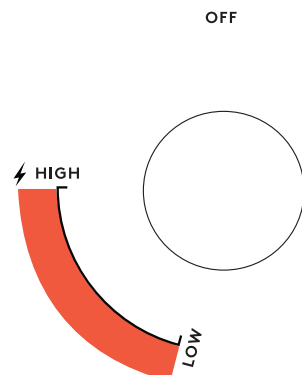

Figure 3D

**NOTE:** When the wok burner is turned to low only the small inner ring stays lit. This is a normal function of the dual wok burner to provide a very low power flame option.

In the absence of electrical power, carry out the ignition directly to the burner with a hand held ignition source.

Both rings of the wok burner operate in the highlighted range of knob rotation.

**NOTE:** Gas controls turn anticlockwise from 'OFF' and have limited movement

Note: The above diagrams are for explanatory purposes only. Your Gas Cooktop may appear slightly different, however the functions remain the same.

# Burners

## CHOICE OF BURNER

For your convenience there is a choice of burners to choose from:

- A small Auxiliary burner for special low heat and slow cooking.
- A medium Semi-Rapid burner for normal cooking and simmering.
- A large Rapid burner for fast heating and large pots and pans.
- A Triple Ring wok burner for very fast heating using a wok or large pot or pan.

To conserve gas place the pan centrally over the burner and adjust the flame so that it does not extend past the edge of the pan (Figure 4). Do not boil food too rapidly. A vigorous boil will not cook food any faster, and will waste energy.

## POTS AND PANS

All common pots and pans; aluminium, stainless steel, cast iron, ceramic, etc., may be used on your new gas cooktop. Ensure that the pots or pans are steady and have flat bases to avoid dangerous spill-over of hot liquids and wasted energy.

### CAUTION:

Never use asbestos mats, wire mats or grids, or aluminium foil as it can lead to overheating, cracked enamel or broken glass. The warranty will be void if these items are used and cause a failure. Woks should only be used on the wok burner and the wok support trivet. Refer to Figure 1A – 1D on page 6 depending on your model.

Figure 4



### INCORRECT

A flame that is too high will cause gas wastage along with possible damage to your handles.



### CORRECT

A correct flame height will save gas usage.



### CORRECT

For a large burner, use a large utensil.



### CORRECT

For a small burner, use a small utensil.

# Cleaning and Care

---

**CAUTION:** Ensure the appliance is off and cool before cleaning.

## TRIVETS

Persistent stains may require rubbing with a nylon scourer or creamed powder cleansers. Household enamel cleaners are available, follow the manufacturer's instructions in their use.

**Harsh abrasive cleaners, powder cleaners, steel wool or wax polishes should not be used.**

## STAINLESS STEEL HOB

Simply wipe with a soft cloth using warm water and a mild detergent and rinse with clean water. Where stainless steel has become extremely dirty or discoloured, use a stainless steel cleaner – but be sure to follow the brushing lines.

**CAUTION:** Do not use abrasive cleaners or harsh solvents.

**IMPORTANT:** Do not use scrapers to clean your hob – it will cause damage.

**CAUTION:** Try to clean up and remove spillages immediately, while the hob is still hot! Especially sugar and foods with a high sugar content (eg. jam), melted plastics and foil, all of which can damage the hob if left.

## GLASS (ON MODELS WITH DECORATIVE GLASS PANEL)

The specialty glass used within the product is toughened and designed for both safety and reliability. However, it must be remembered that as it is **GLASS**, it may break. Treat it accordingly. To clean the glass panel use a soft cloth or sponge with detergent and warm water.

## TRIVETS AND BURNERS

These can all be lifted off and removed for separate cleaning.

**NOTE:** When refitting the burners, ensure that they are correctly seated.

Ensure burners are thoroughly dried after cleaning or spillage. When cleaning the burners, ensure that all the flame ports are free of any blockage (refer to Figure 2B on page 7). If necessary, use a toothpick or brush to clear ports. The outer surface of the burner caps have a polished finish and extra care needs to be taken to avoid scratching this surface during cleaning. In instances of heavy soiling, it may be necessary to apply a non-abrasive cleaning compound and rub with a cloth until the soiling is removed and then finish with a soft, dry cloth.

**NOTE:** NEVER place trivets or burners in the dishwasher.

## IGNITION SPARK PLUG AND FLAME SAFEGUARD SENSOR

**GENTLY** clean the ignition spark plug and flame safeguard sensor with a damp cloth to avoid lighting difficulties. Ensure that they are dry before use.

## INJECTOR

Ensure the injector remains free of any foreign material. If necessary, use a thin piece of wire to clear the orifice.

# Troubleshooting

If you have a problem with the cooktop, check the table below. You may be able to solve the problem and this will save you from paying for a service call. You will have to pay for a service call even in the warranty period if the problem is one listed below.

**TABLE 1**

PROBLEM	POSSIBLE CAUSE	SOLUTION
Burner will not light even though the sparker is working	Knob not held down long enough in 'HIGH' position for flame safeguard.	Repeat lighting procedure and hold knob down for 5 seconds in 'HIGH' position. (Refer page 8).
	Gas supply valve turned off.	Turn on gas supply to appliance.
	Wrong knob turned.	Ensure the knob you are turning corresponds to the burner you want to light.
	Port blockage in ignition area.	Ensure that ports in ignition area are clean and dry.
	Ignition spark plugs wet or dirty.	Dry or clean ignition spark plugs.
No spark is obtained when control knob is activated	Electricity supply is disconnected or switched off.	Switch on electricity or check fuses.
	Ignition spark plugs wet or dirty.	Dry or clean ignition spark plugs.
Flames uneven or tending to lift	Flame ports blocked or wet.	Clean or dry flame ports.
	Burner cap incorrectly fitted.	Ensure this component is fitted correctly.
Flames not staying on when knob is released	Knob not held down long enough in 'HIGH' position for flame safeguard to engage.	Repeat lighting procedure and hold knob down for 5 seconds in 'HIGH' position. (Refer page 9).
	Knob not set between 'HIGH' and 'LOW'	Knob MUST be set between these positions.
	Dirt or spillage on flame safeguard sensor.	Clean flame safeguard sensor tip.
Low heat, slow cooking	Incorrect cooking pot or pan being used.	Refer to Figure 4 (page 10).
Benchtop or knobs overheating	Incorrect cooking pot or pan being used.	Refer to Figure 4 (page 10).
	Pot or pan not located on burner properly.	Ensure pot or pan is centrally located on burner.
Cooktop stainless steel discoloured	Pot or pan being used is too large.	Ensure pot sizes used are as per user manual requirements. Clean with STEEL POWER (available through spare parts).

# Technical Data

We reserve the right to alter these specifications. This appliance conforms to AS/NZS 5263.

**TABLE 2**

FEATURES	ICG6F	ICGW61F	ICGW60S	ICGW70S
Burners	4	4	4	5
Wok	No	Yes, triple ring Wok	Yes, triple ring Wok	Yes, triple ring Wok
Ignition	220–240V	220–240V	220–240V	220–240V
Trivet	Enamel	Cast Iron	Cast Iron	Cast Iron
Hob Material	Stainless Steel	Stainless Steel	Stainless Steel	Stainless Steel
Features	Ignition under knob	Ignition under knob	Ignition under knob	Ignition under knob
Flame Failure Safety	Yes	Yes	Yes	Yes
Colours	Stainless Steel	Stainless Steel	Stainless Steel	Stainless Steel
Gas Types	NG (LP conversion kit supplied)	NG (LP conversion kit supplied)	NG (LP conversion kit supplied)	NG (LP conversion kit supplied)

## COOKTOP PHYSICAL DIMENSIONS (mm)

Width	600	580	580	700
Depth	510	500	500	510
Height	40	40	40	40

## CUT OUT DIMENSIONS (mm)

Width	560	560	560	560
Depth	480	480	480	480

## ENERGY RATING (NG) – MJ/H

Auxiliary burner	1.8–3.8	1.8–3.8	1.8–3.8	1.8–3.8
Semi Rapid burner	3.24–6.5	3.24–6.5	3.24–6.5	3.24–6.5
Rapid burner	5.4–10.8	N/A	N/A	5.4–10.8
Wok burner	N/A	6.3–14.4	6.3–14.4	6.3–14.4
Total MJ/h	27.6	31.2	31.2	42.0

# Installation Instructions

This appliance must be installed by an authorised person and in compliance with:

- AS/NZS 5601.1 Gas Installations Part 1: General Installations, and AS/NZS 5601.2 Gas Installations Part 2: LP Gas installations in caravans and boats for non-propulsive purposes, or the relevant installation code for gas appliances in your country.
- The local gas fitting regulations, municipal building codes, electrical wiring regulations and any other relevant statutory regulations.
- The particular instructions as given below.
- A certificate of compliance **MUST** be given to the customer after the application is successfully installed.

**CAUTION:** Cooktops are supplied set up for natural gas (NG). To use on LPG, the injectors must be changed using the conversion kit supplied. Refer LPG Conversion on page 22.

Figure 5A – ICG6F

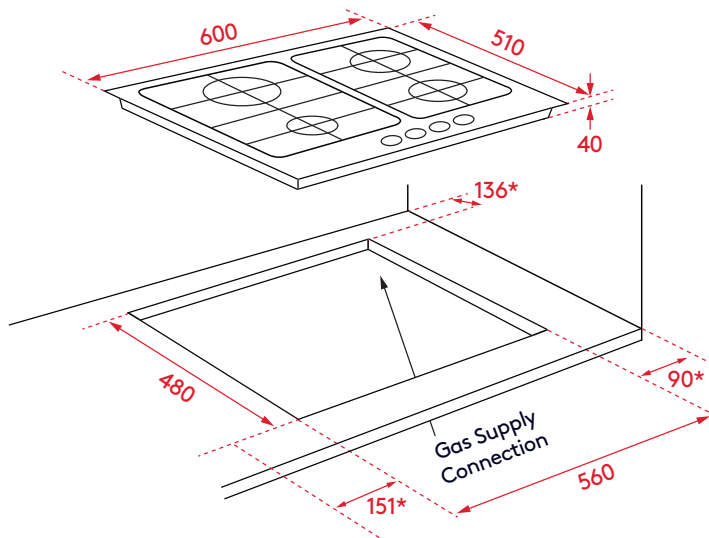
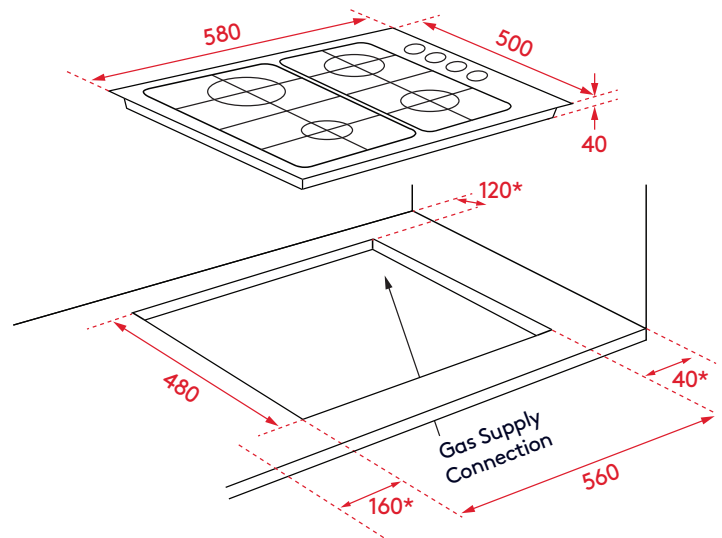

Figure 5B – ICGW61F



\* Minimum clearance from cut-out to combustable surface.

**NOTE:** This dimension is not relevant if the adjacent surface is non-combustible.

Figure 5C – ICGW60S

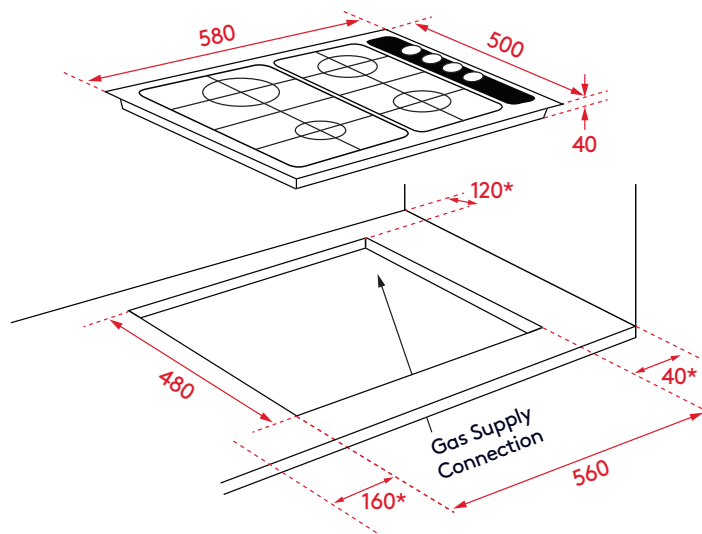
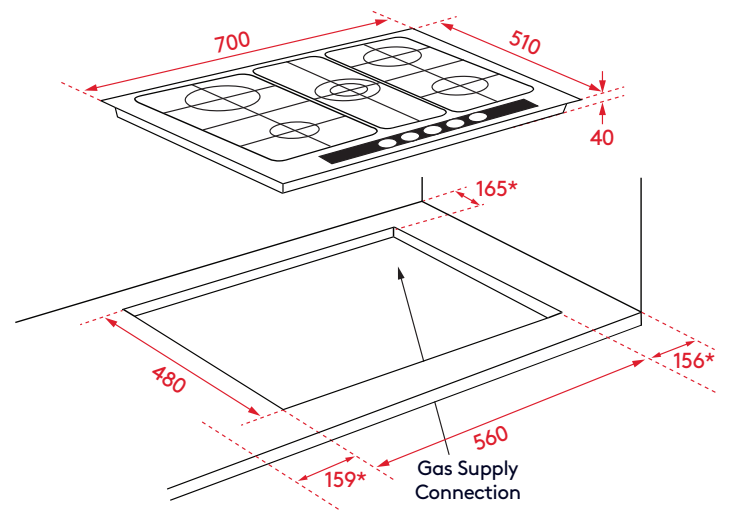

Figure 5D – ICGW70S



\* Minimum clearance from cut-out to combustible surface.

**NOTE:** This dimension is not relevant if the adjacent surface is non-combustible.

# Installation Procedure

---

- The bench cutout should be made as per cutout dimensions in Table 2 and Figure 5A – 5D (depending on your model).
- **Adjacent walls, cupboards and protection for combustible materials:** Ensure that the appliance is installed in accordance with AS/NZS 5601.1, or AS/NZS 5601.2 with regard to clearances to combustible surfaces and materials, and clearances to rangehoods and exhaust fans.
- Ensure that there is an earthed power outlet within 900mm of the rear left hand side of the cooktop when installed. This should be accessible at all times.
- A self-adhesive Foam Tape has been provided to act as a sealing agent and is to be placed around the edge of the hob underside. Ensure that there are no gaps in the Foam Tape. Take care to ensure that the seals meet without overlapping. The thickness of this Foam Tape is 3mm and the width is 10mm.
- Fit the pull down clamps supplied to ensure that the cooktop cannot move after installation. Refer to Figure 6 and the instructions below.
- Remove any excess seal visible after installation.

To ensure clearances of 200mm from burners to vertical combustible surfaces observe the minimum distance requirements shown in Figure 5A-5D (relevant to your model).

Clearances to combustible surfaces may be reduced if combustible surfaces are protected in accordance with AS/NZS 5601.1, or AS/NZS 5601.2.

- **Barrier:** A barrier must be installed to prevent accidental contact with the cooktop base, where the base of the cooktop is accessible from below (i.e. Inside a cupboard, etc.). A minimum clearance of 15mm must be maintained between the base and the barrier. This barrier may be made of any non-combustible, rigid material.

Barrier protection is not necessary if the product is installed above an underbench oven or similar appliance and/or if the cupboard construction is such that the underside of the cooktop is not accessible.

**WARNING:** Failure to fix the cooktop to the bench could result in loosening of the gas connection through movement of the cooktop and a gas leak may result.

Clamps and screws are supplied with each cooktop. Fit the clamps as shown in Figure 6.

When benchtops are less than 35mm in thickness, it may be necessary to fit a spacer between the benchtop and each clamp to ensure clamps can be tightened sufficiently.



Figure 6

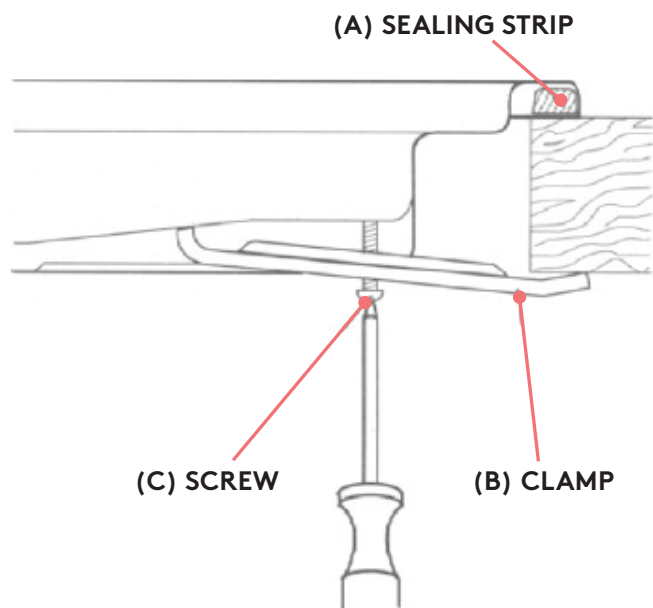

### FITTING THE CLAMPS

- Ensure that the hob is free from all burner pieces and trivets. Place the hob upside down on a soft surface to protect both the hob and your worksurface from damage.
- Place the bracket (B) over the holes that match the size of the screws. There are one set of screw holes in each corner of the hob. Slightly tighten a screw (C) through the bracket (B) so that the bracket is attached to the hob whilst still allowing you to adjust it's position.
- Carefully turn the hob back over and then gently lower it into the aperture hole that you have cut-out in your benchtop.
- On the underside of the hob, adjust the brackets into a position that is suitable for your benchtop. Then fully tighten the screws (C) to secure the hob into position.

# Gas Connection

---

## OPERATION ON N.G./S.N.G

This appliance is supplied for use with Natural Gas. However, it can be converted for use with LPG. Refer to LPG Conversion on page 22.

## SUPPLY PIPE SIZING

The total hourly gas consumption for the appliance is shown on the data label. The required supply pressure (i.e. at inlet to appliance regulator) for each gas type is shown on the data label, and given in Table 3 (page 21). Use this information in conjunction with the length of run, number of elbows, tees and bends, the available service pressure and the supply requirements of other installed appliances to determine a suitable pipe size.

For assistance in this matter refer to the appropriate section of AS/NZS 5601.1 or AS/NZS 5601.2.

An AGA certified class B or D flexible connection may be used to connect the cooktop in accordance with AS/NZS 5601.1, in particular section 5.9 and clause 6.10.1.8, or AS/NZS 5601.2, in particular section 2.11.

Where a hose assembly is used and the cooktop is in the installed position, the hose assembly shall be suitable for connection to a fixed consumer piping outlet located at a point 800 – 850mm above the floor and in the region outside the width of the appliance to a distance of 250mm. The point of connection to consumer piping must be accessible with appliance installed.

## ELBOW POSITIONING

It is possible to reposition the elbow if required by loosening the locking nut and elbow by using two spanners. Re-tighten the entire assembly after the elbow has been repositioned. When fitting elbow to appliance, ensure that the sealing washer is fitted.

**Note to Installer:** Assembly of elbow to manifold at rear of unit requires two spanners to secure locking nut and ensure leak free connection. For this reason the elbow is best secured onto cooktop manifold before installing unit into benchtop.

## REGULATOR

A Dual Gas Regulator is provided, factory set for use with Natural Gas. The regulator must be positioned so that the pressure test nipple is accessible when the appliance is installed.

Connect the gas supply to the ½” B.S.P. internal thread inlet of the regulator. Refer to ‘bench cutout’ Figure 5A-5D (relevant to your model) for connection point position. Regulators are supplied pre-adjusted and configured by the component maker for use with Natural Gas.

The appliance installer is not required to make an adjustment to obtain the correct outlet pressure setting.

An arrow on the base of the regulator indicates the direction of gas flow when the inlet and outlet of the regulator is orientated correctly. When the regulator has been fitted check for leaks from the connections with soapy water.

## DUAL GAS REGULATOR AND VALVE INTRODUCTION

This product is a low-pressure pipeline regulator valve, built-in voltage regulator for gas products. Natural gas and LPG conversion function, need to be set manually.

Operating Temperature: -20~60°C

Inlet pressure setting:  
of natural gas 6 in.wc / liquefied gas 11 in.wc of.

### CONVERTING THE REGULATOR

The Dual Gas Regulator has been factory set to natural gas. To convert the Regulator for use with liquefied petroleum gas, follow the steps below.

1. Using a special tool, open the top cover of the regulator by screwing counter-clockwise (Figure 7A). Figure 7B shows the Factory set state of the top cover with adapter.
2. Remove the adapter from the top cover (Figure 7C).
3. Invert the adapter within the top cover as per Figure 7D.
4. Reinsert the top cover into the Regulator.

**NOTE:** Do not adjust the regulator valve body piece in the above procedure, as it will affect the performance parameters set in the factory.

**WARNING:** The regulator valve outlet pressure has been set at the factory. Please do not adjust it in order to avoid the potential occurrence of a safety accident. If you find any abnormality with the regulator valve, stop use immediately and contact our After Sales Service Team for assistance and replacement.

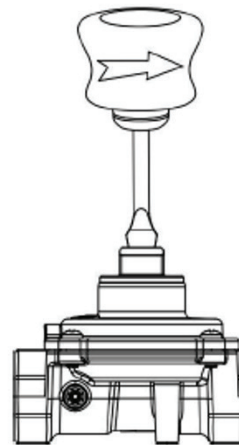

Figure 7A



Figure 7B



Figure 7C



Figure 7D

# Gas Connection (Continued)

## ASSEMBLY OF THE REGULATOR

The assembly of the regulator to the cooktop manifold is achieved via the elbow union and sealing washer supplied, refer to Figure 8.

The ½” parallel thread connects to the manifold, and the sealing washer is placed between the manifold end and the flat face on the elbow.

The ½” tapered thread connects to the outlet of the regulator, and is sealed on the thread using approved thread sealing tape or approved thread sealing compound.

The inlet of the regulator is a ½” parallel thread and is connected to consumer piping or hose assembly.

Regulators are supplied pre-adjusted and configured by the component maker for use with Natural Gas.

The appliance installer is not required to make an adjustment to obtain the correct outlet pressure setting.

An arrow on the base of the regulator indicates the direction of gas flow when the inlet and outlet of the regulator is orientated correctly. When the regulator has been fitted check for leaks from the connections with soapy water.

Figure 8A

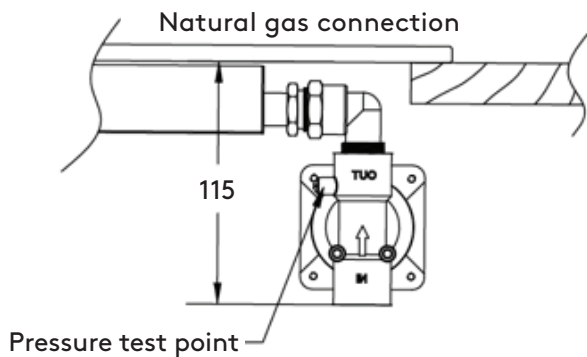
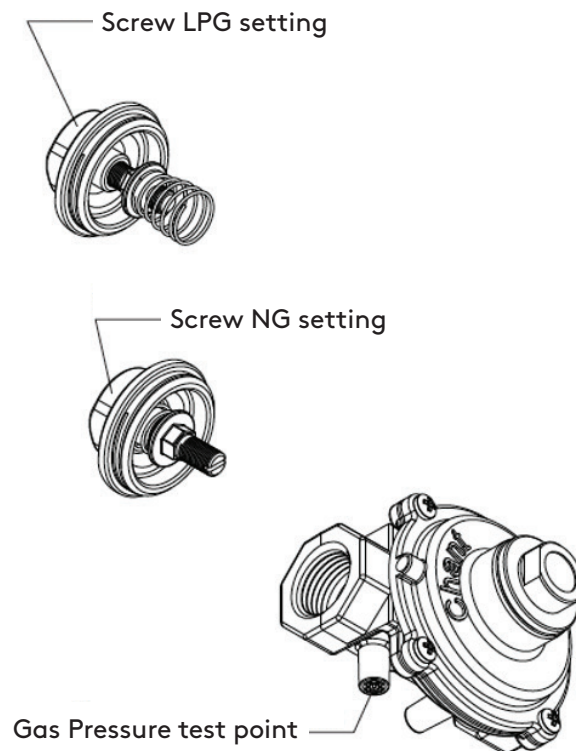

Figure 8B



## CHECKING THE GAS SUPPLY

- Check the manometer zero point is correct.
- Connect the manometer to the cooktop pressure point. This is located on the regulator.
- Turn on the gas supply and electricity and try to ignite the gas.

**NOTE:** It will take additional time to light the gas for the first time as air needs to be purged from the pipes.

With the appliance operating check the outlet pressure:

- When all burners of the appliance are operating at maximum,
- When the smallest burner of the appliance is operating at minimum.

Under these conditions the outlet pressure should not vary from the nominal outlet pressure of 1.00kPa by more than  $\pm 0.20$ kPa.

If the regulator appears to not be performing satisfactorily, then check the following points:

- If the outlet pressure is consistently too low then the inlet pressure may be too low and adjustment of an upstream regulator may be needed, or an upstream regulator or valve with insufficient flow capacity may be present in the gas supply line. If this is suspected then it may be necessary to repeat the checks whilst measuring both the inlet and outlet pressure to determine if the inlet pressure is in the range 1.13 – 5kPa.
- Check that the regulator has been fitted to the gas supply line in the correct orientation, the arrow on the base of the body indicates the direction of gas flow.

Once these checks have been completed, if the regulator still fails to perform in a satisfactory manner it should be replaced.

**TABLE 3**

Burner Type	Natural Gas (Nominal Test point pressure: 1.00kPa)		LPG (Nominal Test point pressure: 2.75kPa)	
	Injector Size (mm)	Gas Consumption (MJ/h)	Injector Size (mm)	Gas Consumption (MJ/h)
Auxiliary burner	0.85	1.8–3.8	0.53	1.8–3.7
Semi Rapid burner	1.16	3.24–6.5	0.72	3.24–6.6
Rapid burner	1.49	5.4–10.8	0.93	5.4–11.0
Wok burner	1.80	6.3–14.4	1.07	6.3–14.7

# LPG Conversion

---

This appliance is supplied set up for Natural Gas usage. A conversion kit is included with the product for Universal LPG usage. The conversion kit contains the appropriate injectors, 1 Dual Gas Regulator (which incorporates a Test Point) and 1 LPG sticker.

Please follow the procedure below if a conversion to suit UNIVERSAL LPG is required:

- Remove the hotplate trivets, burner caps and burner crowns to access the hotplate injectors. Replace the factory fitted injectors with the appropriate injectors, as supplied. Refer to injector orifice table for injector sizes. The injector size is stamped on the side of the injector.
- Follow the steps within this User Manual to set the Dual Gas Regulator for LPG and connect using approved gas thread tape or compound to the elbow fitting.
- Turn on the gas supply and at each new connection check for leaks using soapy water. Each hotplate valve should be turned on, one at a time, and the injector hole blanked off for several seconds.
- With the appliance operating check the outlet pressure when all burners of the appliance are operating at maximum, when the smallest burner of the appliance is operating at minimum.  
Under these conditions the outlet pressure should not vary from the nominal outlet pressure of 2.60kPa by more than  $\pm 0.52\text{kPa}$ .
- If the regulator appears to not be performing satisfactorily then check the following points:
- If the outlet pressure is consistently too low then the inlet pressure may be too low and adjustment of an upstream regulator may be needed, or an upstream regulator or valve with insufficient flow capacity may be present in the gas supply line.
- If this is suspected then it may be necessary to repeat the checks whilst measuring both the inlet and outlet pressure to determine if the inlet pressure is in the range 2.75 – 7.00kPa.
- One by one, turn the knobs to minimum and screw in the bypass screw (accessible when the knob is removed) until a small stable flame results; a length of 3-4mm. Turn the knob to maximum and then back to minimum to ensure that the correct minimum flame is maintained.
- Attach the LPG sticker to the cooker, near the gas supply inlet. Cover the Natural Gas label that is factory fitted.

# Electrical Connection

## ELECTRICAL CONNECTION (220-240 VOLTS)

The appliance is supplied with a standard 7.5 Amp service cord terminated by a 3-pin plug for connection to a standard 10 Amp household socket. The electrical supply is required to power the electronic ignition system.

**NOTE:** It will be necessary for servicing purposes to disconnect the electrical power supply. The power point should therefore be accessible after the appliance is installed, as specified in the local wiring regulations.

Diagram 1 is a schematic of the wiring in the appliance.

## IMPORTANT:

- This appliance must be earthed.
- This appliance is designed to be connected to a 220-240V, 50Hz-60Hz AC electricity supply.
- The wires in the mains lead are coloured in accordance with the following code:
  1. Green/Yellow = Earth
  2. Blue = Neutral
  3. Brown = Live

**IMPORTANT:** The wire which is coloured Green/Yellow must be connected to the terminal which is marked with the letter E or by the Earth symbol.

**WARNING:** When the power cord is damaged it must be replaced by the manufacturer, its service agent or similarly qualified persons in order to avoid a hazard.

Diagram 1:  
ICG6F, ICGW61F, ICGW60S, ICGW70S

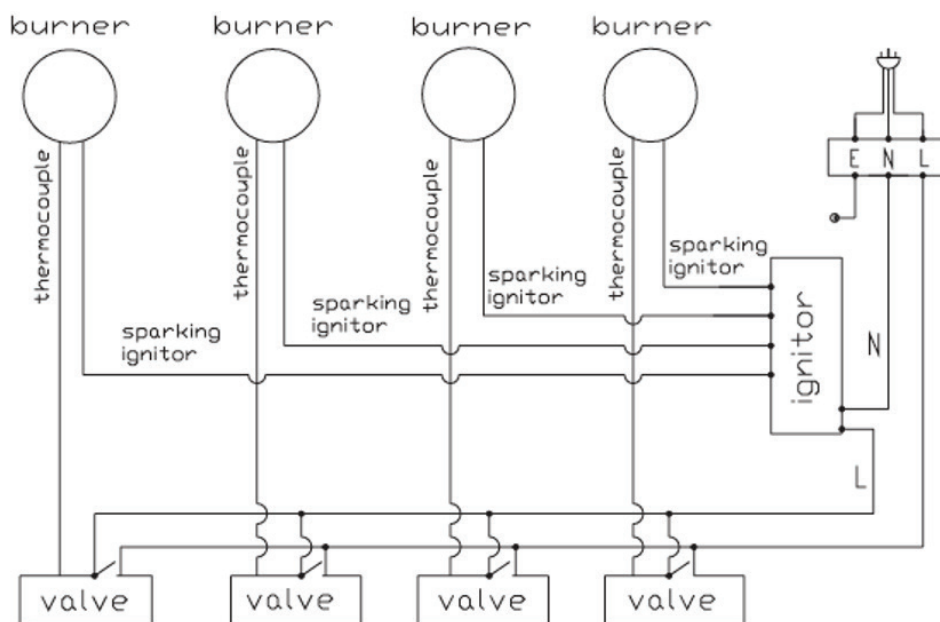

# Testing Appliance Operation

---

After installation, test the appliance and ensure that it operates correctly before handing it over to the customer. The following procedure is recommended:

- Turn on the gas and electricity supply and attempt ignition on all burners, both separately and in combination. (For correct procedure refer to page 8). Note that additional time needs to be allowed for the initial lighting as air has to be purged from the pipes.
- Observe the flame appearance on each burner (Figure 9). If it is much larger or much smaller than expected, the injector size and supply pressure require checking. Where a flame is unsatisfactory, refer to the Troubleshooting Guide (page 12) to correct the fault. If the Troubleshooting Guide does not solve the problem, please call the Service Centre.
- When all the foregoing is satisfactory, check the turndown (minimum or low) setting on each burner, as this may need adjustment. Valves have a bypass controlling screw, which may be accessed by removing the knob. This screw will be located on a particular area of the valve (refer Figure 10). Normally, this will have been correctly set at the factory for use on Natural Gas (NG) and should not require adjustment.

**IMPORTANT:** If the appliance has been converted to LPG, then the bypass screw will **HAVE** to be screwed in until a small, stable flame results.

**Please ensure the supply pressure has been checked PRIOR to any adjustment.**

- If the appliance cannot be adjusted to perform safely inform the customer of the problem and affix an appropriate warning notice to the appliance. If the fault appears to be dangerous the appliance should be disconnected. If a minor fault exists, the customer may wish to use the appliance while awaiting service.

If a fault cannot be fixed, please call the Service Centre.

- The customer should be advised that, in the event of a fault, the local service organisation or the retailer from whom the appliance was purchased should be contacted.
- When satisfied that the unit is operating correctly, turn off and instruct the customer on correct operation as outlined in this booklet. Ask the customer to operate the controls to ensure that the correct procedure is understood.

**CAUTION:** Servicing must only be carried out by an authorised service person.

Injector sizes required for various gas types are shown in Table 3 (page 21). The appliance test point pressure for each gas type is also shown.

For model identification after installation, an additional data plate sticker has been provided. This sticker is to be stuck onto adjacent cabinetry.



Figure 9

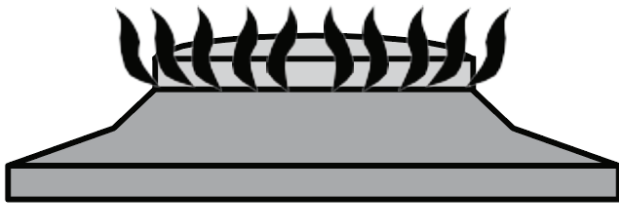

Flame size adjusted to maximum

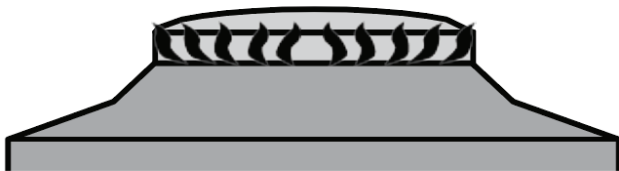

Flame size adjusted to minimum

Figure 10

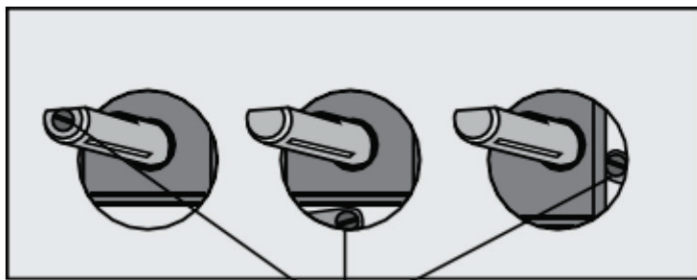

Bypass screw

Attach your receipt  
to this page



# Purchase Details

---

For future reference, please record the following information which can be found on the rating plate and the date of purchase which can be found on your sales invoice.

## STORE DETAILS

---

STORE NAME | \_\_\_\_\_

ADDRESS | \_\_\_\_\_

TELEPHONE | \_\_\_\_\_ PURCHASE DATE | \_\_\_\_\_

## PRODUCT DETAILS

---

MODEL NO. | \_\_\_\_\_

SERIAL NO.\* | \_\_\_\_\_

# Warranty Information

## AUSTRALIAN WARRANTY TERMS & CONDITIONS COOKING APPLIANCES

This document sets out the terms and conditions of the product warranties for Residentia Group Appliances. It is an important document. Please keep it with your proof of purchase documents in a safe place for future reference should you require service for your Appliance.

### 1. IN THIS WARRANTY

- (a) 'acceptable quality' as referred to in clause 10 of this warranty has the same meaning referred to in the ACL;
  - (b) 'ACL' means Trade Practices Amendment (Australian Consumer Law) Act (No.2) 2010;
  - (c) 'Appliance' means any Residentia Group product purchased by you accompanied by this document;
  - (d) 'ASR' means Residentia Group authorised service representative;
  - (e) 'Residentia Group' means Residentia Group Pty Ltd of 165 Barkly Avenue Burnley VIC, ACN 600 546 656 in respect of Appliances purchased in Australia;
  - (f) 'major failure' as referred to in clause 10 of this warranty has the same meaning referred to in the ACL and includes a situation when an Appliance cannot be repaired or it is uneconomic for Residentia Group, at its discretion, to repair an Appliance during the Warranty Period;
  - (g) 'Warranty Period' means:
    - (i) where the Appliance is used for personal, domestic or household use (i.e. normal single family use) as set out in the instruction manual, the Appliance is warranted against manufacturing defects for 24 months (or 36 months where a valid extended warranty registration has occurred), following the date of original purchase of the Appliance;
    - (h) 'you' means the purchaser of the Appliance not having purchased the Appliance for re-sale, and 'your' has a corresponding meaning.
2. This warranty only applies to Appliances purchased and used in Australia and is in addition to (and does not exclude, restrict, or modify in any way) any non-excludable statutory warranties in Australia.
  3. During the Warranty Period Residentia Group or its ASR will, at no extra charge if your Appliance is readily accessible for service, without special equipment and subject to these terms and conditions, repair or replace any parts which it considers to be defective. Residentia Group or its ASR may use remanufactured parts to repair your Appliance. You agree that any replaced Appliances or parts become the property of Residentia Group. This warranty does not apply to light globes, batteries, filters or similar perishable parts.
  4. Parts and Appliances not supplied by Residentia Group are not covered by this warranty.
  5. You will bear the cost of transportation, travel and delivery of the Appliance to and from Residentia Group or its ASR. If you reside outside of the service area, you will bear the cost of:
    - (a) travel of an authorised representative;
    - (b) transportation and delivery of the Appliance to and from Residentia Group or its ASR, in all instances, unless the Appliance is transported by Residentia Group or its ASR, the Appliance is transported at the owner's cost and risk while in transit to and from Residentia Group or its ASR.
  6. Proof of purchase is required before you can make a claim under this warranty.
  7. You may not make a claim under this warranty unless the defect claimed is due to faulty or defective parts or workmanship. Residentia Group is not liable in the following situations (which are not exhaustive):

- 
- (a) the Appliance is damaged by:
- (i) accident
  - (ii) misuse or abuse, including failure to properly maintain or service
  - (iii) normal wear and tear
  - (iv) power surges, electrical storm damage or incorrect power supply
  - (v) incomplete or improper installation
  - (vi) incorrect, improper or inappropriate operation
  - (vii) insect or vermin infestation
  - (viii) failure to comply with any additional instructions supplied with the Appliance;
- (b) the Appliance is modified without authority from Residentia Group in writing;
- (c) the Appliance's serial number or warranty seal has been removed or defaced;
- (d) the Appliance was serviced or repaired by anyone other than Residentia Group, an authorised repairer or ASR.
8. This warranty, the contract to which it relates and the relationship between you and Residentia Group are governed by the law applicable where the Appliance was purchased.
9. To the extent permitted by law, Residentia Group excludes all warranties and liabilities (other than as contained in this document) including liability for any loss or damage whether direct or indirect arising from your purchase, use or non use of the Appliance.
10. For Appliances and services provided by Residentia Group in Australia, the Appliances come with a guarantee by Residentia Group that cannot be excluded under the Australian Consumer Law. You are entitled to a replacement or refund for a major failure and for compensation for any other reasonably foreseeable loss or damage. You are also entitled to have the Appliance repaired or replaced if the Appliance fails to be of acceptable quality and the failure does not amount to a major failure. The benefits to you given by this warranty are in addition to your other rights and remedies under a law in relation to the Appliances or services to which the warranty relates.
11. At all times during the Warranty Period, Residentia Group shall, at its discretion, determine whether repair, replacement or refund will apply if an Appliance has a valid warranty claim applicable to it.
12. Missing parts are not covered by warranty. Residentia Group reserves the right to assess each request for missing parts in a case by case basis. Any parts that are not reported missing in the first week after purchase will not provide free of charge.
13. To enquire about claiming under this warranty, please follow these steps:
- (a) carefully check the operating instructions, user manual and the terms of this warranty;
  - (b) have the model and serial number of the Appliance available;
  - (c) have the proof of purchase (e.g. an invoice) available;
  - (d) telephone the numbers shown below.
14. You accept that if you make a warranty claim, Residentia Group and its ASR may exchange information in relation to you to enable Residentia Group to meet its obligations under this warranty.
- IMPORTANT**  
Before calling for service, please ensure that the steps in point 13 have been followed.
- Telephone contact
- Service: Please call 1300 11 HELP (4357)
- 

**The Australian Consumer Law requires the inclusion of the following statement with this warranty:**  
Our goods come with guarantees that cannot be excluded under the Australian Consumer Law. You are entitled to a replacement or refund for a major failure and for compensation for any other reasonably foreseeable loss or damage. You are also entitled to have the goods repaired or replaced if the goods fail to be of acceptable quality and the failure does not amount to a major failure.

THIS PAGE IS INTENTIONALLY LEFT BLANK

# Warranty Information

## NEW ZEALAND WARRANTY TERMS & CONDITIONS COOKING APPLIANCES

To help care for your investment, be sure to register your appliance online. Registration will help you if you need to arrange service in the future, and serves as a record of your purchase – including critical information like model number and serial number – that you can refer to at any time.

Simply visit the below website, or ask your retailer for help: [www.inalto.house/nz/registration](http://www.inalto.house/nz/registration)

### WARRANTY:

These products are covered by a warranty for a period of 24 months from the date of purchase, subject to the following conditions\*. The warranty covers rectification free of charge of any fault arising from defective materials or components, or faulty workmanship or assembly.

\* The conditions above mentioned are:

1. That the purchaser carefully follows all instructions packed with the product;
2. That the purchaser and/or installer carefully follows the installation instructions provided and complies with electrical wiring regulations, gas and/or plumbing codes;
3. That the purchaser carefully follows instructions provided in the owner's handbook relating to the proper use and care of the product and does not use the product for any purpose other than the domestic use for which it has been designed;
4. Commercial use of the product for professional or industrial purposes will void this warranty.;
5. That the product was purchased and installed in New Zealand;
6. That this warranty does not extend to:
  - a) optional glass lids for hobs apart from claims which relate to mechanical or physical damage thereof at the date of purchase;
  - b) 'consumable' parts such as light bulbs or filters;
  - c) damage to ceramic glass caused by liquid or solid spill-overs, lack of maintenance, or impact;
  - d) damage to surface coatings caused by cleaning or maintenance using products not recommended by the owner's handbook;
  - e) defects caused by normal wear and tear, accident, negligence, alteration, misuse or incorrect installations;
  - f) a product dismantled, repaired or serviced by any serviceman other than an authorised service agent;

- g) a product not in possession of the original purchaser;
- h) damage caused by power outages or surges
- i) damage caused by pests (eg. rats, cockroaches etc.)

7. That if the product is a freestanding microwave oven or small appliance it must be returned to the dealer/retailer for servicing. These products, unless stated otherwise, have a 12 month warranty from original date of purchase with 24 months on the microwave magnetron; Waste disposers have a 12 month warranty.
8. The provision of service under this warranty is limited by a 25km boundary from the retailer where the product was purchased except for microwaves. Such travelling outside of these limits will incur commercial cost to be paid by you, regulated by the number of kilometres travelled beyond the 25km limit (50km return trip). Microwaves are to be delivered to the nearest authorised service agent by the customer.

Please refer to your user manual for any further conditions that may apply to your specific model.

Nothing herein contained shall be construed in any way as excluding or limiting your rights under the Consumer Guarantees Acts 1993.

For Service please visit [www.applico.co.nz/service](http://www.applico.co.nz/service) or contact the dealer/retailer from whom you purchased the product from or call the 0800 number listed below. If you are unable to establish the date of purchase, or the fault is not covered by this warranty, or if the product is found to be in working order, you will be required to bear all service call charges.

Registration of this warranty constitutes acceptance of the terms and conditions of this warranty.

Should you require any assistance, please call Customer Services on 0800 763 448.

Distributed by Applico Ltd.  
[www.applico.co.nz](http://www.applico.co.nz)  
July 2019

After registering your appliance online, we recommend you fill out the below information for your reference and keep this warranty card in a safe place.

**THIS WARRANTY IS VALID IN NEW ZEALAND ONLY.**

DESIGNED IN MELBOURNE

INALTO?

FOR ALL AUSTRALIAN HOMES

---

WWW.INALTO.HOUSE



E2447